

BILL OF MATERIAL

ITEM NO	DESCRIPTION	MATERIAL	QTY
1	JAM NUT	304SS	16
2	END FLANGE	CPVC	2
3	SIGHT GLASS	BOROSILICATE	1
4	TIE ROD	304SS	4
5	TIE ROD COVER	PLASTIC	4
6	SIGHT GLASS SHIELD	POLYCARBONATE	1
7	GASKET	TEFLON	2

NOTES:
 1- TEMPERATURE RATING: 70°F
 2- PRESSURE RATING: 150

- SUBMITTAL ACTION
- FURNISH AS SUBMITTED
 - FURNISH AS CORRECTED
 - REVISE AND RESUBMIT
 - REJECTED

DATE _____ BY _____

Ø.75 THRU EQUALLY
 SPACED ON A Ø4.75 BOLT
 CIRCLE, 4 PLACES
 (2" ANSI 150lb DRILLING)

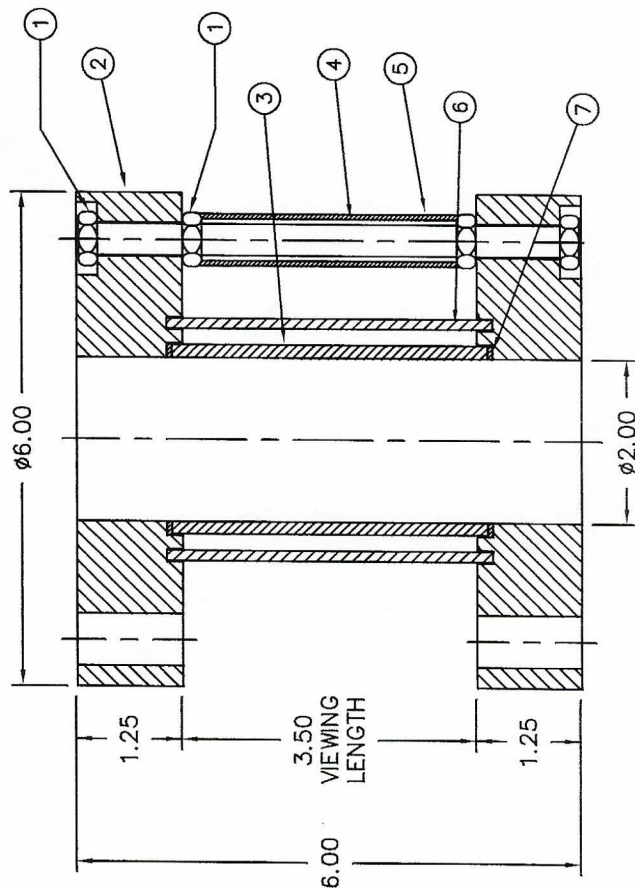
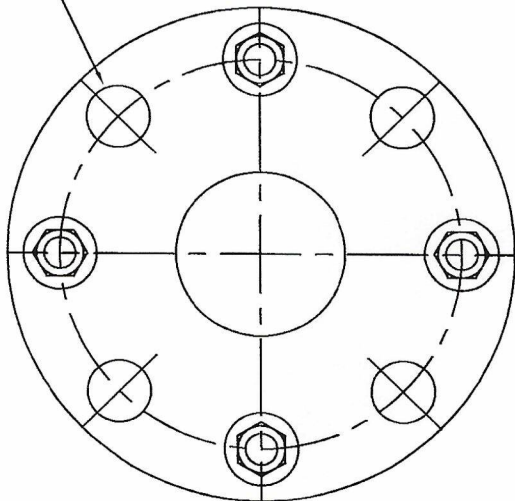

No.	LTR.	REVISION/DESCRIPTION	DATE	CHECKED BY

CF CHEM FLOWTRONICS

195 PATERSON AVE
 LITTLE FALLS, NJ 07424
 PHONE: (973) 785-0001
 FAX: (973) 785-8051

CUSTOMER:

50mm MODEL 300P
 SIGHT FLOW INDICATOR

DRAWN BY	CHECKED BY	DATE	SCALE	REV. LTR.
		08/18/06	1	1

DWG. No. SF-300P-CPVC-50 SHEET No. 1 OF 1

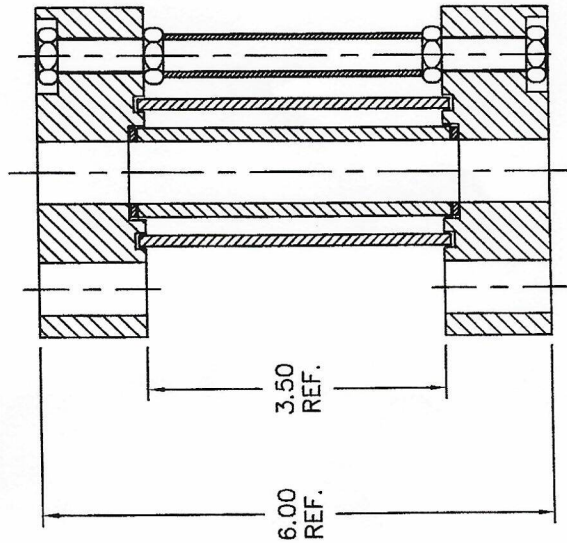
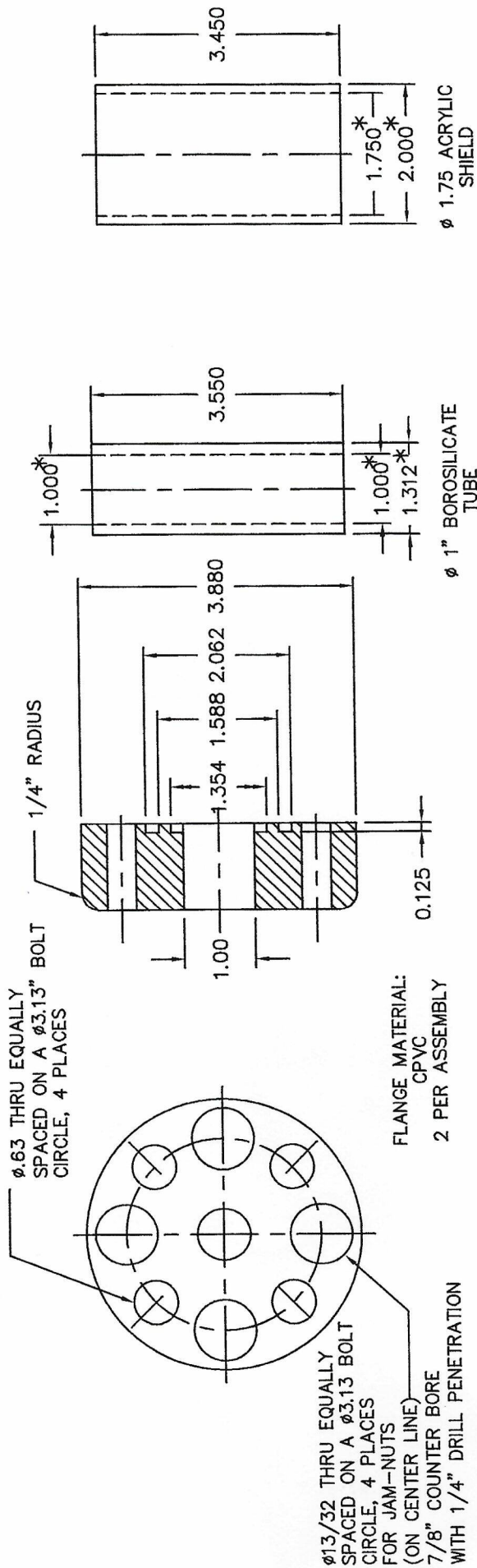

COMPLETED ASSEMBLY

NOTES:
 1- DIMENSIONS ARE IN INCHES.
 2- TOLERANCE UNLESS NOTED: ± 0.005

*- REF. DIMENSIONS

No.	LTR	REVISION/DESCRIPTION	DATE	CHECKED BY

CF CHEM FLOWTRONICS
 195 PATERSON AVE
 LITTLE FALLS, NJ 07424
 PHONE: (973) 785-0001
 FAX: (973) 785-8051
 CUSTOMER :

25mm MODEL 300P
 SIGHT FLOW INDICATOR

DRAWN BY	CHECKED BY	DATE	SCALE	REV LTR.
NT		08/31/06	1	1

M-300P-CPVC-25
 1 OF 1
 SHEET No.

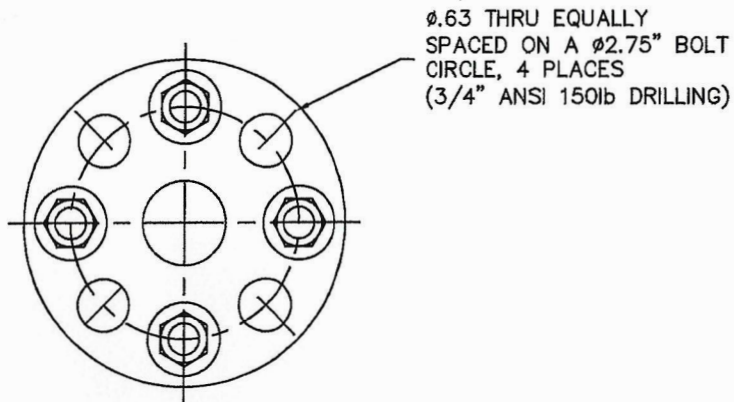

BILL OF MATERIAL			
ITEM NO	DESCRIPTION	MATERIAL	QTY
1	JAM NUT	304SS	16
2	END FLANGE	CPVC	2
3	SIGHT GLASS	BOROSILICATE	1
4	TIE ROD	304SS	4
5	TIE ROD COVER	PLASTIC	4
6	SIGHT GLASS SHIELD	POLYCARBONATE	1
7	GASKET	TEFLON	2

NOTES:
 1- TEMPERATURE RATING: 70°F
 2- PRESSURE RATING: 150

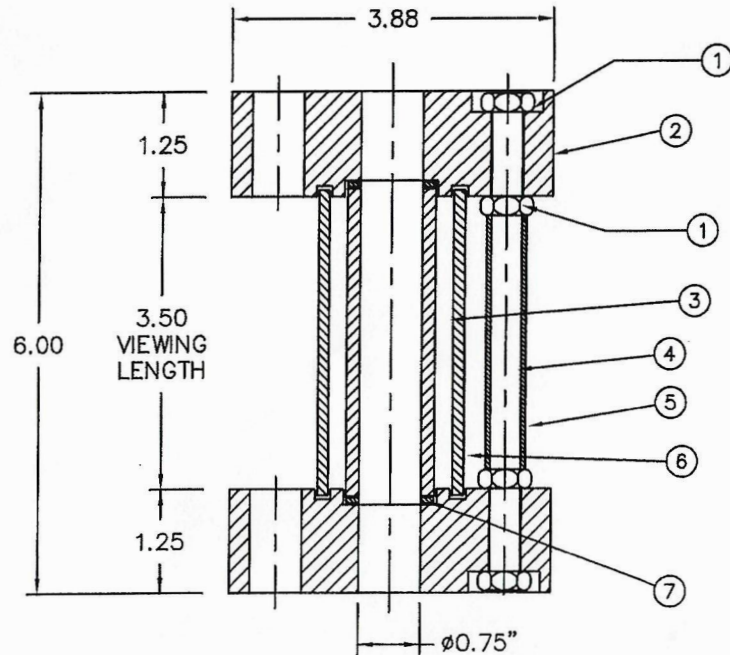

SUBMITTAL ACTION	
<input type="checkbox"/>	FURNISH AS SUBMITTED
<input type="checkbox"/>	FURNISH AS CORRECTED
<input type="checkbox"/>	REVISE AND RESUBMIT
<input type="checkbox"/>	REJECTED
DATE _____	BY _____

No.	LTR	REVISION/DESCRIPTION	DATE	CHECKED BY
195 PATERSON AVE PHONE: (973) 785-0001 LITTLE FALLS, NJ 07424 FAX: (973) 785-8051				
CUSTOMER :				
18mm MODEL 300P SIGHT FLOW INDICATOR				
NT		08/23/06	1 = 1	
DWG. No.	CHECKED BY	DATE	SCALE	REV LTR.
SF-300P-CPVC-18				1 OF 1
				SHEET No.